

TM 5-4320-255-13

DEPARTMENT OF THE ARMY TECHNICAL MANUAL

**OPERATOR'S, ORGANIZATIONAL
AND DIRECT SUPPORT, MAINTENANCE MANUAL**

**INCLUDING
REPAIR PARTS AND SPECIAL TOOL LIST**

**PUMP
CENTRIFUGAL, PNEUMATIC, SUMP, 210 GPM
(INGERSOLL-RAND MODEL 251)**

FSN 4320-021-1351

This copy is a reprint which includes current
pages from Change 1.

**HEADQUARTERS, DEPARTMENT OF THE ARMY
5 SEPTEMBER 1969**

Change }
No. 1

HEADQUARTERS
DEPARTMENT OF THE ARMY
Washington, D.C., 20 March 1973

**Operator's, Organizational
And Direct Support Maintenance Manual
Including
Repair Parts And Special Tool List
PUMP, CENTRIFUGAL PNEUMATIC; SUMP; 210-GPM
(INGERSOLL-RAND MODEL 251) FSN 4320-021-1351**

TM 5-4320-255-13, 5 September 1969, is changed as follows:

P-ii. After page ii, add the following:

INTRODUCTION

1-1. Scope

These instructions are published for the use of the personnel to whom the centrifugal pump is issued.

1-2. Maintenance Forms and Records

Maintenance forms, records, and reports which are to be used by maintenance personnel at all maintenance levels are listed in and prescribed by TM 38-750.

1-3. Destruction of Material to Prevent Enemy Use

Instructions for destruction of material to prevent enemy use will be found in TM 740-244-3.

1-4. Administrative Storage

Instructions for preparation for shipment and limited storage will be found in TM 740-90-1.

1-5. Reporting of Errors

The reporting of errors, omissions, and recommendations for improving this manual by the individual user is encouraged. Reports should be submitted on DA Form 2028 (Recommended Changes to Publications) and forward direct to Commander, US Army Mobility Equipment Command, ATTN: AMSME-MPP, St. Louis, MO 63120.

Page A-1. Appendix A is superseded as follows:

**APPENDIX A
BASIC ISSUE ITEMS LIST AND ITEMS
TROOP INSTALLED OR AUTHORIZED**

Section I. INTRODUCTION

A-1. Scope

This appendix lists items required by the operator for operation of the centrifugal pump.

A-2. General

This list is divided into the following sections

a. Basic Issue Items List - Section II. Not applicable.

b. *Items Troop Installed or Authorized List - Section III.* A list of items in alphabetical sequence, which at the discretion of the unit commander may accompany the centrifugal pump. These items are NOT SUBJECT TO TURN-IN with the centrifugal pump when evacuated.

A-3. Explanation of Columns

The following provides an explanation of columns in the tabular list of Basic Issue Items List Section II, and Items Troop Installed or Authorized, Section III.

a. *Source, Maintenance and Recoverability Code (SMR).* Not applicable.

b. *Federal Stock Number.* This column indicates

the Federal stock number assigned to the item and will be used for requisitioning purposes.

c. *Description.* This column indicates the Federal item name and any additional description of the item required.

d. *Unit of Measure (U/M).* A two character alphabetic abbreviation indicating the amount or quantity of the item upon which the allowances are based, e.g., ft, ea, pr, etc.

e. *Quantity Furnished with Equipment (BIIL).* Not applicable.

f. *Quantity Authorized (Items Troop Installed or Authorized).* This column indicates the quantity of the item authorized to be used with the equipment.

SECTION III. ITEMS TROOP INSTALLED OR AUTHORIZED LIST

(1) SMR code	(2) Federal stock number	(3) Description Ref. No. & Mfr code	(4) Unit of meas	(5) Qty auth
	7520-559-9618 4930-277-2909	CASE: Maintenance and Operation manuals OILER: Airline	EA EA	1 1

By Order of the Secretary of the Army:

Official:

VERNE L. BOWERS

Major General, *United States Army*
The Adjutant General

CREIGHTON W. ABRAMS
General, *United States Army*
Chief of Staff

Distribution:

To be distributed in accordance with DA Form 12-25A (qty rqr block No. 242) organiaational maintenance requirements for Pumps, Fresh Water.

TECHNICAL MANUAL
NO. 5-4320-255-13

HEADQUARTERS
DEPARTMENT OF THE ARMY
WASHINGTON D.C., 5 September 1969

Operator, Organizational, and Direct
Support Maintenance Manual, Including Repair Parts and
Special Tools List

PUMP, CENTRIFUGAL, PNEUMATIC, SUMP,
210 GPM (INGERSOLL-RAND MODEL P251)
FSN 4320-021-1351

	Page
General Description	1
Preparation For Use	1
Specifications	1
Operating Instructions	2
Preventive Maintenance	2
Troubleshooting	2
Disassembly	3
Assembly	3-4
Appendix A - Basic Issue Items List	A-1
Appendix B - Maintenance Allocation Chart	B-1
Appendix C - Repair Parts List	C-1
Section I Introduction	

- Section II Prescribed Load Allowance
- Section III Repair Parts For Organizational Maintenance
 - Group 01 - Sump Pump
- Section IV Special Tools, Test and Support Equipment For Organizational Maintenance
"NOT APPLICABLE"
- Section V Repair Parts For MS Maintenance
 - Group 01 - Sump Pump
- Section VI Special Tools, Test and Support Equipment For DS Maintenance
"NOT APPLICABLE"
- Section VII Federal Stock Number and Reference Number Index

GENERAL DESCRIPTION

The Size 2.51 Pneumatic Centrifugal Pump is ideal for general pumping work such as pumping out caissons, cofferdams, tanks, bilges, sumps and trenches. They are completely submersible and are designed to handle clear or dirty water, oil, sewage or moderately heavy sludge.

Reliable, trouble & free service is assured by pressurized lubrication of the impeller shaft seals, efficient closed-type impeller, specially treated double water seals, powerful governed multi-vane motor and protective air strainer. The Arbor is machined from stainless steel to prevent corrosion and the possible resultant rust bond between the Rotor and Arbor.

The water Seals are suitable for liquids of temperatures up to 210°F.

With the pump operating on 80 p.s.i. air pressure, the actual water delivery through 50 ft. of 2½" Fire Hose for various lifts is as follows: --

Total Heed feet	Delivery g.p.m.
10	260
20	240
30	225
40	210
50	195

PREPARATION FOR USE

Recommended Lubricants

Grease, GAA; MIL-G-10924

Lubricating Oil, Engine: Grade 1, MIL-L-21260

Before placing a pump in service, unscrew the Oil Chamber Plug (37) and fill the oil chamber in the Back Head (36) with the recommended oil.

Squirt 15 or 20 drops of oil into the air inlet before attaching the air hose.

Unscrew the caps from the three Grease Fittings (3 and 40) and insert the recommended grease with a

Grease Gun. Two or three strokes of the Grease Gun is sufficient for the two Fittings nearest the air inlet. The remaining fitting is the means of filling the chamber of the built-in grease lubricator. Insert grease until the chamber is filled; a full chamber is indicated by Grease emerging from the Grease Level Valve (5). Be sure to replace the caps on the Fittings.

A ¾" air hose, assembled with a No. UM-75-M Hose Coupling for connecting it to the pump, is recommended. Use of smaller hose and fittings will restrict the air with subsequent loss in Pump efficiency.

Use of an air line oiler is recommended for lubricating the pump motor. the air line oiler as close to the tool as possible. Adjust the oiler so that there is a slight mist in the exhaust.

NOTE: Larger capacity units may be used, but do not use a unit having less than ¾" pipe tap inlet and outlet.

Specifications

Height	Size Opening Pump Will Enter	Weight	Air Inlet Pipe Tap	Air Exhaust Pipe Tap	Discharge Pipe Tap	Size Exhaust Hose	Size Discharge Hose
Inches	Inches	Lbs.	Inches	Inches	Inches	Inches	Inches
22¾	9½x11¾	65-5/8	¾	1¼	2½	1½	2½

OPERATING INSTRUCTIONS

The 251 Sump Pump can be completely submerged, but a water-tight exhaust hose (1½" dia. hose) to the surface of sump liquid should be maintained at all times. For installations requiring deeper submergence, additional lengths of the same or larger diameter hose can be used; under no circumstances should smaller hose be used as it will restrict the exhaust and impair the efficiency of the Pump.

When pumping from a ditch or sump, set the Pump on a board or flat stone or suspend it a few inches off the bottom of the sump. The less mud, sand and gravel pumped, the longer the Pump will last.

If the water is very dirty, protect the Pump by setting it in a mesh basket, or screen it in by some other method.

Should the inlet become clogged, lift the Pump from the water and stop the motor. Water running back through the discharge hose will usually flush the dirt from the Inlet.

The rate of flow from the oil chamber to the motor is regulated by a filter vent plug (39) The oiler is correctly set at the factory, but since flow varies somewhat with temperature and oil viscosity, adjustment may sometimes be necessary. The Pump motor should use about ½ cup of oil for each four hours of operation.

To regulate the oiler, remove the Back Head (36) and turn the filter vent plug located in the face of the Back Head. Turning the plug in decreases the flow; backing the Plug out increases the flow. Under no circumstances should the Plug be backed out beyond the face of the Back Head.

PREVENTIVE MAINTENANCE

After each four hours of operation, unless an air line lubricator is used, replenish the chamber in the Back Head (36) with oil.

Weekly, or as experience dictates, insert grease, following the same procedure as recommended in "Preparation for Use."

At regular intervals, shut off the air supply and unscrew the Air Strainer Plug (34) from the Air Strainer Cap (33). Be sure that no one is in line with the opening in the Cap. Then turn on the air momentarily. After the accumulated dirt is blown from the Air Strainer Screen (35), shut off the air and replace the Plug. Occasionally, unscrew the Air Strainer Cap from the body, withdraw the Screen and wash it in Kerosene or other solvent. Frequency of cleaning the Air Strainer depends on the condition of the air line.

TROUBLE SHOOTING OR INSPECTION FOR WEAR OR DAMAGE

For the most efficient operation of the Pump, particularly against high heads, it is necessary that the clearance between the Impeller (56) and the Impeller Cover (52) be limited. This clearance is set at .010" at the factory. When, due to wear, this clearance has increased to about 1/32", an adjustment can be made by removing enough of the Impeller Cover Shims (53) to obtain the original .010" clearance. This simple adjustment will prolong the life of Impeller and maintain the high efficiency of the Pump. The Impeller Cover Shims (53) are different colors to identify the various thicknesses. White is .025", brown is .010", blue is .005" and green is .003".

After long service, it may be necessary to remove some of the Impeller Shims (46) to eliminate excessive clearance between the hub of the Impeller (56) and the face of the Impeller Hub Bushing (2). To make the adjustment, remove the Impeller and remove some of the Impeller Shims from the Arbor (47). Replace the Impeller and tighten the Arbor Nut (54). Rotate the Impeller. Repeat this procedure until enough shims have been removed to cause a slight drag on the Impeller. Then add one .010" Shim. Note: After removing the Impeller Shims, be sure to adjust the Impeller Cover to obtain the .010" clearance as explained in the preceding paragraph.

The Governor is adjusted at the factory to produce an Impeller speed of approximately 5200 rpm. After long service, some parts may become worn to the extent that readjustment of the Governor is necessary to maintain the rated speed.

To readjust the Governor, turn the Governor Adjusting Nut (24) on the Governor Stem (21). One half turn of the Nut varies the speed approximately 50 rpm. Screwing the Nut farther onto the Governor Stem increases the speed; backing it off decreases the speed.

Adjusting a new or reassembled Governor so that dimension "A" shown below is 1-13/16" usually results in the proper speed. However, this is only an approximate setting; to obtain the correct setting, a tachometer should be used.

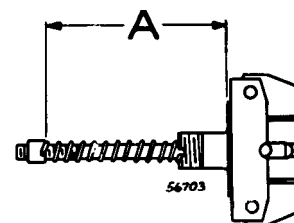

Weight-type Governor
A = 1 13/16" (46 mm)

DISASSEMBLY AND ASSEMBLY

Note: Do not disassemble the Pump any further than is necessary to replace a worn or damaged part. Do not remove any part which is a press fit in or on a subassembly unless the removal of that part is necessary for replacement or repairs. This refers specifically to the Arbor Front Bearing (44) and Arbor Bearing Spacer (25), as the Bearing is usually destroyed during removal.

Also avoid unnecessary removal of the Arbor Packing Retainers (10) and Arbor Packing (9) from the Front End Plate (8). Arbor Packings are impregnated with tallow. If new ones are being installed, they must be heated slightly so that they can be compressed sufficiently for insertion in the Front End Plate.

DISASSEMBLY

1. Unscrew the Air Strainer Assembly (32) from the Back Head (36). For cleaning and disassembly of the Air Strainer Assembly follow the procedure as recommended in "Preventive Maintenance".
2. Unscrew the Impeller Cover Cap Screws (49) and remove the Inlet (51), Impeller Cover (52) and Impeller Cover Shims (53). Unscrew the Arbor Nut (54) from the Arbor (47). This can usually be loosened by a sharp, quick blow on the handle of a wrench placed upon the Nut. The Impeller (56) can usually be removed by pulling with the fingers while lightly striking the threaded end of the Arbor with a hammer handle or wood block. Remove the Impeller Key (48) and Impeller Shims (46) from the Arbor.
3. Grasp the Housing (1) in a vise. Using a soft hammer, strike the lugs on the Housing Nut (16), loosening the Nut. Unscrew the Nut and remove the Back Head (36) and Housing Gasket (15). Remove the motor assembly by driving on the threaded end of the Arbor with a soft hammer. Remove the Impeller Spacer (45) if this part remained in the Water Seals (4). Place the Housing, motor end down, on the work bench.

Examine the Impeller Hub Bushing (2) and the Water Seals (4). Do not remove these parts unless they are unfit for further service.

4. Grasp the Impeller end of Arbor in copper covered vise jaws and unscrew the Governor Assembly from the opposite end of the Arbor. The Governor Body (17) has a left-hand thread; turn clockwise to remove. Remove the assembly from the vise and insert a 5/16" diameter rod at least 5" long into the hole from which

the Governor was removed. Hold the Cylinder in one hand (never clamp it in a vise) and strike the rod, driving the Arbor from the Arbor Rear Bearing (26) and freeing the Rear End Plate (14), Cylinder (43), Rotor (42), Vanes (1 1), Front End Plate (8) and Arbor Bearing Spring (58). As recommended in "Disassembly and Assembly" the Arbor Front Bearing (44), Arbor Bearing Spacer (25), Arbor Packing Retainers (10) and the Arbor Packing (9) should not be removed unless replacement is necessary. To remove the Arbor Packing Retainers, which hold the Packing in place, use the No. P35-54 Retainer Pliers.

5. Unscrew the Grease Chamber Cap (65) from the Housing and remove the Grease Plunger Spring (63) and Grease Plunger (64). Examine the Grease Plunger Packing (62) and the Grease Chamber Cap Seal (66). Replace either if worn or damaged.

ASSEMBLY

1. Slip the Grease Chamber Cap Seal (66) over the threaded end of the Grease Chamber Cap (65) until it enters the groove in front of the flange on the Cap. Mount the Grease Plunger Packing (62) on the front face of the Grease Plunger (64) and retain it with the Grease Plunger Packing Washer (61) and Grease Plunger Packing Washer Cap Screw (59). Slide the Plunger, Packing end first, into the Grease Chamber, insert the Grease Plunger Spring (63) and screw the Cap into the end of the chamber.
2. As stated under "Disassembly and Assembly", the Arbor Packing must be heated slightly before insertion in the Front End Plate. Place an Arbor Packing Retainer (10) followed by the Arbor Packing (9) into the Front End Plate. Retain by installing the other Packing Retainer.
3. Be sure the Arbor Bearing Spacer (25) is in position against the shoulder on the Arbor (47) before installing the duplex type Arbor Front Bearing (44). Press one bearing component, shielded side first, against the Spacer with a sleeve that will contact only the bearing inner ring. Press the remaining component, open side first, against the first component, again using the sleeve so that all pressing is done on the inner ring.
4. Position the Arbor Bearing Spring (58) so that its pronged side contacts the outer ring of the Arbor Front Bearing (44). Then install the Front End Plate (8) on the Arbor.

5. Slide the Arbor (47), into the larger of the rotor orifices, engaging the spline on the Arbor with the mating internal spline in the Rotor (42).
6. After installing a Vane (11) in each vane slot, place the Cylinder (43) over the Rotor and onto the Front End Plate, positioning it so that the small hole in the face of the Cylinder and the notch in the cylinder flange align with the small hole and notch in the End Plate.
7. Slip the Rear End Plate (14), crescent grooved side first, over the end of the Arbor and install the Arbor Rear Bearing (26).
8. Screw the Governor Assembly into the bore of the Arbor. This is a left-hand thread, turn counterclockwise to tighten.
9. When installing the Water Seals, position the Housing, motor end down, and start one of the Water Seals (4), lip side first, into the housing bore (the spring is visible on the lip side). Using a flat faced arbor, whose diameter nearly equals that of the Seal, press in the Seal until its leading face is flush with the bottom of the small bore in the Housing. Start the second Seal, lip side up, into the housing bore. Then press in the Impeller Hub Bushing (2) until its flange contacts the housing face. As the Bushing enters the Housing it will force the second Seal into the proper position.
10. Insert the Impeller Spacer (45), beveled end first, into the bore of the Water Seals from the motor end of the Housing. Insert the Arbor Front Bearing Seat (57) through the motor chamber in the Housing and seat it on the shoulder adjacent to the Water Seal.
11. Stand the Housing upright on the Impeller chamber to enter the arbor and motor assembly. If care is used to maintain good alignment, the assembly will slide readily into position. Never drive or otherwise force the motor into the Housing.
12. Slide the Housing Gasket (15) over the face and against the shoulder on the Back Head (36). Slide the pilot on the Back Head into the Housing, entering the end of the Cylinder Dowel (13), that protrudes from the Rear End Plate, into the dowel hole in the face of the Back Head. Retain by screwing the Housing Nut (16) securely onto the Housing. Rotate the Arbor as the Housing Nut is tightened. If binding is noted it is usually due to the motor being improperly seated in the Housing. Striking the Housing a few blows with a soft hammer will usually jar the motor to a good seat and eliminate the binding.
13. Lubricate the Pump More starting it even momentarily. Without lubrication the Water Seals will be quickly damaged.
14. Check the Arbor speed with a tachometer. If found incorrect, reset the Governor as stated under "Inspection for Wear or Damage".
15. Install the Impeller (56) on the Arbor, and the Impeller Cover (52) on the Housing, being sure to adjust the clearance in accordance with the procedure recommended under "Inspection for Wear or Damage".

ILLUSTRATION NUMBER	PART NAME
	Parts Indentad After An Item Are Included With That Item
1	Motor Housing
2	Impeller Hub Bushing
3	Grease Fitting(2)
4	Water Seal(2)
5	Grease Level Valve
6	Vent Fitter(2)
7	Vent Filter Plug
8	Front End Plate
9	Arbor Packing
10	Arbor Packing Retainer(2)
11	Vane(4)
12	Dead Handle
13	Cylinder Dowel
14	Rear End Plate
15	Housing Gasket
16	Housing Nut
	Governor Ammbly
17	Governor Body
18	Go vernor Weight Pin(2)
19	Governor Stem Washer
20	Govemor Weight(2)
21	Governor Stem
22	Governor Stem Pin
23	Governor Spring
24	Governor Adjusting Nut
25	Arbor Bearing Spacer
26	Arbor Rear Bearing (Special; purchase from Ingersoll-Rand)
27	GovernorValve
28	GovernorValveSpring
29	Governor Valve Spring Seat.
30	Seat Retaining Spring
31	Air Strainer Nipple
32	Air Strainer Assembly
33	Air Strainer Cap
34	Air Strainer Plug
35	Air Strainer Screen
36	Back Head
37	Oil Chamber Plug.
38	Vent Filter (2)
39	Vent Filter Plug
40	Grease Fitting
41	Governor Valve Bushing
42	Rotor
43	Cylinder
44	Arbor Front Bearing(M.R.C. No.304 SF-DB or its equivalent)
45	Impeller Spacer
46	Impeller Shim(3)
	.005"(.127mm)thick
	.010"(.254mm)thick
	.025"(.635mm)thick
47	Arbor
48	Impeller Key
49	Impeller Cover Cap Screw(4)
50	3/8"LockWasher(4)
51	Inlet
52	Impeller Cover

ILLUSTRATION NUMBER (Do not use for ordering)	PART NAME FOR ORDERING Parts Indented After An Item Are Included With That Item
53	Impeller Cover Shim (as required; see "IMPELLER ADJUSTMENT" on page 2) .003" (.076mm)thick; green.005" (.127mm) thick; blue010"(.254mm)thick; brown025"(.636mm)thick; white
54	Arbor Nut
55	Arbor Nut Washer
56	Impeller
57	Arbor Front Bearing Seat
58	Arbor Bearing Spring
59	Grease Plunger PackingWasher Cap Screw
60	5/16"Lock Washer
61	Grease Plunger Packing Washer.
62	Grease Plunger Packing
63	Grease Plunger Spring.
64	Grease Plunger
65	Grease Chamber Cap
66	Grease Chamber Cap Seal
*	Fire Hose Adapter
*	Exhaust Adapter
*	Reducing Bushing
*	Hose Coupling

*Not illustrated.

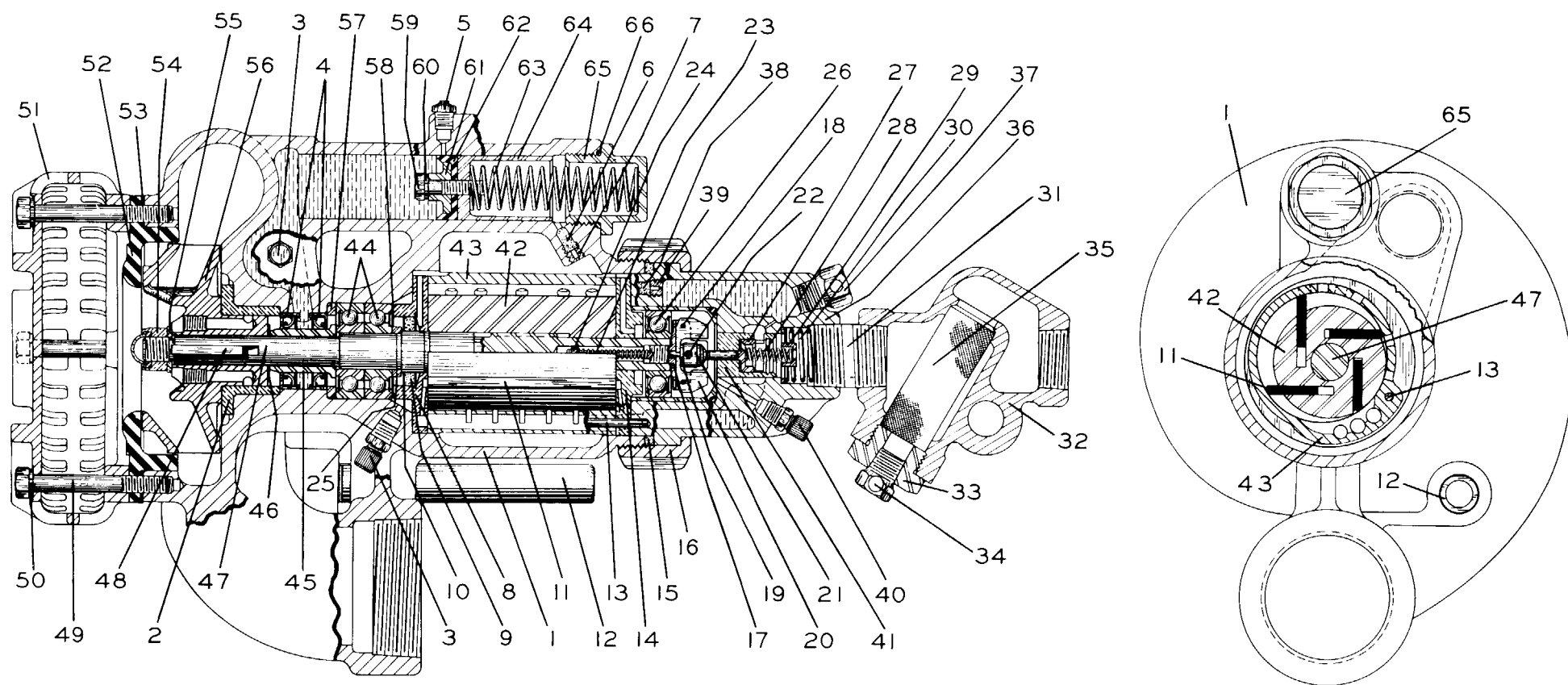

Figure 1. Sump pump.

APPENDIX A

BASIC ISSUE ITEMS LIST

Section I. INTRODUCTION

A-1. Scope

This appendix lists items which accompany the sump pump or are required for installation, operation, or operator's maintenance.

A-2. General

This Basic Issue Items List is divided into the following sections:

- a. Basic Issue Items - Section II. A list of items which accompany the sump pump and are required by the operator/crew for installation, operation, or maintenance.
- b. Maintenance and Operating Supplies - Section III. A listing of maintenance and operating supplies required for initial operation.

A-3. Explanation of Columns

The following provides an explanation of columns in the tabular list of Basic Issue Items, Section II.

- a. Source, Maintenance, and Recoverability Codes (SMR):

(1) Source code, indicates the selection status and source for the listed item. Source codes are:

Code	Explanation
P	Repair parts which are stocked in or supplied from the GSA/DSA, or Army supply system and authorized for use at indicated maintenance categories.
P2	Repair parts which are procured and stocked for insurance purposes because the combat or military essentiality of the end item dictates that a minimum quantity be available in the supply system.
M	Repair parts which are not procured or stocked, but are to be manufactured in indicated maintenance levels.

Code	Explanation
A	Assemblies which are not procured or stocked as such, but are made up of two or more units. Such component units carry individual stock numbers and descriptions, are procured and stocked separately and can be assembled to form the required assembly at indicated maintenance categories.
X	Parts and assemblies which are not procured or stocked and the mortality of which normally is below that of the applicable end item or component. The failure of such part or assembly should result in retirement of the end item from the supply system.
X1	Repair parts which are not procured or stocked. The requirement of such items will be filled by use of the next higher assembly or component.
X2	Repair parts which are not stocked. The indicated maintenance category requiring such repair parts will attempt to obtain them through cannibalization. Where such repair parts are not obtainable through cannibalization, requirements will be requisitioned, with accompanying justification, through normal supply channels.
G	Major assemblies that are procured with PEMA funds for initial issue only as exchange assemblies at DSU and GSU level. These assemblies will not be stocked above GS and DS level or returned to depot supply levels.

(2) Maintenance code, indicates the lowest category of maintenance authorized to install the listed item. The maintenance level code is:

Code	Explanation
C	Operator/crew.

(3) Recoverability code, indicates whether unserviceable items should be returned for recovery or salvage. Items not coded are expendable. Recoverability codes are:

Code	Explanation
R	Applied to repair parts (assemblies and components) which are considered economically repairable at direct and general support maintenance levels. When the maintenance capability to repair these items does not exist, they are normally disposed of at the GS level. When supply considerations dictate, some of these repair parts may be listed for automatic return to supply for depot level repair as set forth in AR 710-50. When so listed, they will be replaced by supply on an exchange basis.
S	Repair parts and assemblies which are economically repairable at DSU and GSU activities and which normally are furnished by supply on an exchange basis. when items are determined by a GSU to be uneconomically repairable they will be evacuated to a depot for evaluation and analysis before final disposition.
T	High dollar value recoverable repair parts which are subject to special handling and are issued on an exchange basis. Such repair parts are normally repaired or overhauled at depot maintenance activities.
U	Repair parts specifically selected for salvage by reclamation units because of precious metal content critical materials, or high dollar value reusable casings or castings.

b. Federal Stock Number. This column indicates the Federal stock number assigned to the item and will be used for requisitioning purposes.

c. Description. This column indicates the Federal item name and any additional description of the item required. The abbreviation "w/e", when used as a part of the nomenclature, indicates the Federal stock number includes all armament, equipment, accessories, and repair parts issued with the item. A part number or other reference number is followed by the applicable five-digit Federal supply code for manufacturers in parenthesis. Repair parts quantities included in kits, sets, and assemblies are shown in front of the repair part name.

d. Unit of Measure (U/M). A 2 character alphabetic abbreviation indicating the amount or quantity of the item upon which the allowances are based, e.g., ft, ea, pr, etc.

e. Quantity Incorporated in Unit. This column indicates the quantity of the item used in the assembly group. A "V" appearing in this column in lieu of a quantity indicates that a definite quantity cannot be indicated (e.g., shims, spacers, etc.).

f. Quantity Furnished With Equipment. This column indicates the quantity of an item furnished with the equipment.

g. Illustration. This column is divided as follows:

(1) Figure Number. Indicates the figure number of the illustration in which the item is shown.

(2) Item Number. Indicates the callout number used to reference the item in the illustration.

A-4. Explanation of Columns in the Tabular List of Maintenance and Operating Supplies - Section III.

a. Component Application. This column identifies the component application of each maintenance or operating supply item.

b. Federal Stock Number. This column indicates the Federal stock number assigned to the item and will be used for requisitioning purposes.

c. Description. This column indicates the item name and brief description.

d. Quantity Required for Initial Operation. This column indicates the quantity of each maintenance or operating supply item required for initial operation of the equipment.

e. Quantity Required for 8 Hours Operation. This column indicates the estimated quantities required for an average 8 hours of operation.

f. Notes. This column indicates informative notes keyed to data appearing in a preceding column.

A-5. Federal Supply Code for Manufacturers

Code	Manufacturer
81349	Military Specifications Promulgated by Standardization Division Direc- torate of Logistic Services DSA

SECTION II. BASIC ISSUE ITEMS

(1) SMR CODE	(2) FEDERAL STOCK NUMBER	(3) DESCRIPTION		(4) UNIT OF MEAS	(5) QTY INC N UNIT	(6) QTY FURN WITH EQUIP	(7) ILLUSTRATION	
		REF NO. & MFR CODE	USABLE ON CODE				(A) FIG NO.	(B) ITEM NO.
		GROUP 31 - BASIC ISSUE ITEMS, MANUFACTURER INSTALLED						
		3100 - BASIC ISSUE ITEMS, MANUFACTURER OR DEPOT INSTALLED						
P C	7520-559-9618	CASE, MAINTENANCE AND OPERA - TIONAL MANUAL MIL-B-11743		EA		1		
		DEPARTMENT OF THE ARMY LUBRICATION ORDER LO 5-4320-255-12		EA		1		
		DEPARTMENT OF THE ARMY TECH- NICAL MANUAL TM 5-4320-255- 13		EA		1		
PC	4930-277-2909	OILER, AIRLINE, BOWL 1 PT, 3/4 IN. INLET AND OUTLET QUICK-DISCONNECT UNIVERSAL COUPLING CONNECTION 0-13417 81349		EA		1		

SECTION III

MAINTENANCE AND OPERATING SUPPLIES

(1) ITEM	(2) COMPONENT APPLICATION	(3) FEDERAL STOCK NUMBER	(4) DESCRIPTION	(5) QUANTITY REQUIRED F/INITIAL OPERATION	(6) QUANTITY REQUIRED F/8 HRS OPERATION	(7) NOTES
	Air Motor	9150-264-3941	Lubricating Oil Engine 5 gal drum	1 pt	1 qt	
		9150-190-0905	GAA, Grease, Automotive and Artillery 5 lb can	1 lb	1 lb	
	Lubricator, Air Line	9150-264-3941	Lubricating Oil, Engine 5 gal drum	1 pt	1 qt	
	Pump	9150-190-0905	GAA, Grease, Automotive and Artillery 5 lb can	1 lb	2 lb	

APPENDIX B
MAINTENANCE ALLOCATION CHART

Section 1. INTRODUCTION

B-1. General

a. This section provides a general explanation of all maintenance and-repair functions authorized at various maintenance levels.

b. Section II designates overall responsibility for the performance of maintenance functions on the identified end item or component. The implementation of the maintenance functions upon the end item or component will be consistent with the assigned maintenance functions.

c. Section III not applicable.

d. Section IV not applicable.

B-2. Explanation of Columns in Section II

a. Group Number. Column 1. The assembly group is a numerical group assigned to each assembly in a top down breakdown sequence. The applicable assembly groups are listed on the MAC in disassembly sequence beginning with the first assembly removed in a top down disassembly sequence.

b. Assembly Group. Column 2. This column contains a brief description of the components of each assembly group.

c. Maintenance Functions. column 3. This column lists the various maintenance functions (A through K) and indicates the lowest maintenance category authorized to perform these functions. The symbol designations for the various maintenance categories are as follows:

- C - Operator or crew
- O - Organizational maintenance
- F - Direct support maintenance
- H - General support maintenance
- D - Depot maintenance

The maintenance functions are defined as follows:

- A - INSPECT . To determine serviceability of an item by comparing its physical, mechanical, and electrical characteristics with established standards.
- B - TEST . To verify serviceability and to detect electrical or mechanical failure by use of test equipment.
- C - SERVICE . To clean, to preserve, to charge, to paint, and to add fuel, lubricants, cooling agents, and air.
- D - ADJUST . To rectify to the extent necessary to bring into proper operating range.
- E - ALIGN . To adjust specified variable elements of an item to bring to optimum performance.
- F - CALIBRATE. To determine the corrections to be made in the readings of instruments or test equipment used in precise measurement. Consists of the comparisons of two instruments, one of which is a certified standard of known accuracy, to detect and adjust any discrepancy in the accuracy of the instrument being compared with the certified standard.
- G - INSTALL. To set up for use in an operational environment such as an emplacement, site, or vehicle.
- H - REPLACE . To replace unserviceable items with serviceable like items.
- I - REPAIR . Those maintenance operations necessary to restore an item to serviceable condition through correction of material damage or a specific failure. Repair may be accomplished at each category of maintenance.
- J - OVERHAUL . Normally, the highest degree of maintenance performed by the Army in order to minimize time work in process is consistent with quality and economy of operation. It consists of that maintenance necessary to restore an item to completely serviceable condition as prescribed by maintenance standards in technical publications for each item of equipment. Overhaul normally does not return an item to like new, zero mileage, or zero hour condition.

K - REBUILD . The highest degree of material maintenance. It consists of restoring equipment as nearly as possible to new condition in accordance with original manufacturing standards. Rebuild is performed only when required by operational considerations or other paramount factors and then only at the depot maintenance category. Rebuild reduces to zero the hours or miles the equipment, or component thereof, has been in use.

d. Tools and Equipment. Column 4. This column is provided for referencing by code the special tools and test equipment, (Section III) required to perform the maintenance functions (Section II).

e. Remarks. Column 5. This column is provided for referencing by code the remarks (Section IV) pertinent to the maintenance functions.

B-3 . Explanation of Columns in Section III

a. Reference Code. This column consists of a number and a letter separated by a dash. The number references the T&TE requirements column on the MAC. The letter represents the specific maintenance function the item is to be used with. The letter is representative of columns A through K on the MAC.

b. Maintenance Category. This column shows the lowest level of maintenance authorized to use the special tool or test equipment.

c. Nomenclature. This column lists the name or identification of the tool or test equipment.

d. Tool Number. This column lists the manufacturer's code and part number, or Federal Stock Number of tools and test equipment.

B-4 Explanation of Columns in Section IV

a. Reference Code. This column consists of two letters separated by 6 dash, both of which are references to Section II. The first letter references column 5 and the second letter references a maintenance function, column 3, A through K.

b. Remarks. This column lists information pertinent to the maintenance function being performed, as indicated on the MAC, Section II.

SECTION II - MAINTENANCE ALLOCATION CHART

FOR

(1) GROUP NO.	(2) FUNCTIONAL GROUP	(3) MAINTENANCE FUNCTIONS											(4) TOOLS AND EQUIPMENT	(5) REMARKS	
		A	B	C	D	E	F	G	H	I	J	K			
		INSPECT	TEST	SERVICE	ADJUST	ALIGN	CALIBRATE	INSTALL	REPLACE	REPAIR	OVERHAUL	REBUILD			
01	Pneumatic, Equipment														
	Motor Assy			C	O			F		F					
	Governor	C		C	O					F					
	Lubricators	C		C				C		O					
02	Pumps														
	Pump Assy	C		C				F		F					
	Shaft, Rotors & Impellers	C		C	O			F		F					
	Suction & or Discharge Assy	C		C				C		O					
	Inlet & Outlet Components	C		C				O	O						

APPENDIX C

Section I. INTRODUCTION

C-1. Scope

This manual lists repair parts, special tools, test and support equipment required for the performance of organizational and direct support maintenance of the sump pump.

C-2. General

This Repair Parts and Special Tools List is divided into the following sections:

a. Prescribed Load Allowance (PLA) - Section II. A composite listing of repair parts, special tools, test and support equipment having quantitative allowances for initial stockage at the organizational level.

b. Repair Parts - Section III. A list of repair parts authorized for the performance of maintenance at the organizational level in figure and item number sequence.

c. Special Tools, Test and Support Equipment - Section IV. Not-applicable.

d. Repair Parts - Section V. A list of repair parts authorized for the performance of maintenance at the direct support level in figure and item number sequence.

e. Special Tools, Test and Support Equipment - Section VI. Not-applicable.

f. Federal Stock Number and Reference Number Index - Section VII. A list of Federal stock numbers in ascending numerical sequence, followed by a list of reference numbers appearing in all of the listings, in alpha-numeric sequence, cross-referenced to the illustration figure number and item number. NOTE: Items not illustrated are cross-referenced to assembly group number.

C-3. Explanation of Columns

The following provides an expansion of columns in the tabular lists in Sections II through IV.

a. Source, Maintenance, and Recoverability Codes (SMR).

NOTE: Common hardware items known to be readily available in Army supply channels are assigned maintenance codes only. Source codes, Recoverability codes, and Maintenance Allowances are not assigned this category.

(1) **Source Code.** Indicates the selection status and source for the listed item. Source codes used are:

Code	Explanation
P	Repair parts which are stocked in or supplied from the GSA/DSA, or Army supply system and authorized for use at indicated maintenance categories.
P2	Repair parts which are procured and stocked for insurance purposes because the combat or military essentiality of the end item dictates that a minimum quantity be available in the supply system.
M	Repair parts which are not procured or stocked, but are to be manufactured in indicated maintenance levels.
A	Assemblies which are not procured or stocked as such, but are made up of two or more units. Such component units carry individual stock numbers and descriptions, are procured and stocked separately and can be assembled to form the required assembly at indicated maintenance categories.
X	Parts and assemblies which are not procured or stocked and the mortality of which normally is below that of the applicable end item or component. The failure of such part or assembly should result in retirement of the end item from the supply system.
X1	Repair parts which are not procured or stocked. The requirement of such items will be filled by use of the next higher assembly or component.
X2	Repair parts which are not stocked, The indicated maintenance category requiring such repair parts will attempt to obtain them through cannibalization. where such repair parts are not obtainable through cannibalization, requirements will be requisitioned, with accompanying justification, through normal supply channels.

Code	Explanation
C	Repair parts authorized for local procurement. Where such repair parts are not obtainable from local procurement, requirements will be requisitioned through normal supply channels accompanied by a supporting statement of nonavailability from local procurement.
G	Major assemblies that are procured with PEMA funds for initial issue only as exchange assemblies at DSU and GSU level. These assemblies will not be stocked above GS and DS level or returned to depot supply level.

(2) Maintenance Code. Indicates the lowest category of maintenance authorized to install the listed item. The maintenance codes are:

Code	Explanation
O	Organizational maintenance
F	Direct support maintenance

(3) Recoverability Code. Indicates whether unserviceable items should be returned for recovery or salvage. Items not coded are expendable. Recoverability codes are:

Code	Explanation
R	Applied to repair parts (assemblies and components) which are considered economically reparable at direct and general support maintenance levels. When the maintenance capability to repair these items does not exist, they are normally disposed of at general support level. When supply considerations dictate, some of these repair parts may be listed for automatic return to supply for depot level repair as set forth in AR 710-50. When so listed, they will be replaced by supply on an exchange basis.
S	Repair parts and assemblies which are economically reparable at DSU and GSU activities and which normally are furnished by supply on an exchange basis. When items are determined by a GSU to be uneconomically reparable they will be evacuated to a depot for evaluation and analysis before final disposition.

Code	Explanation
T	High dollar value recoverable repair parts which are subject to special handling and are issued on an exchange basis. Such repair parts are normally repaired or overhauled at depot maintenance activities.
U	Repair parts specifically selected for salvage by reclamation units because of precious metal content, critical materials, or high dollar value reusable casings or castings.

b. Federal Stock Number. Indicates the Federal stock number assigned to the item and will be used for requisitioning purposes.

c. Description. Indicates the Federal item name and any additional description of the item required. Assembly components and subassemblies are indented under major assemblies. The abbreviation "w/e", when used as a part of the nomenclature, indicates the Federal stock number includes all armament, equipment, accessories, and repair parts issued with the item. A part number or other reference number is followed by the applicable 5-digit Federal supply code for manufacturers in parenthesis. Repair parts quantities included in kits and sets are shown in front of the repair part name. Material required for manufacture or fabrication is identified.

d. Unit of Measure (U/M). A 2 character alphabetic abbreviation indicating the amount or quantity of the item upon which the allowances are based, e.g., ft, ea, pr, etc.

e. Quantity Incorporated in Unit. Indicates the quantity of the item used in the assembly group. A "V" appearing in this column in lieu of a quantity indicates that a definite quantity cannot be indicated (e.g., shims, spacers, etc.).

f. 15-Day Organizational Maintenance Allowance.

(1) The allowance columns are divided into four subcolumns. Indicated in each subcolumn opposite the first appearance of each item is the total quantity of the items authorized for the number of equipments supported. Subsequent appearances of the same item will have the letters "REF" in the allowance column. To locate the referenced item, locate the FSN or reference number in the index. The earliest figure and item number is the referenced item. Items authorized for use as required but not for initial stockage are identified with an asterisk in the allowance column.

(2) The quantitative allowance for organizational level of maintenance represents one initial prescribed load for a 15-day period for the number of equipments supported. Units authorized additional prescribed loads, multiply the number of prescribed loads by the quantity in the appropriate density column to determine the number of repair parts authorized.

(3) To determine allowances when supporting more than 150 of these equipments. First, divide the number of equipments supported by 100 by moving the decimal two spaces left. Second, multiply the result by the quantity in the 51-100 density column. Example, authorized allowance for 51-100 equipments is 12; for 140 equipments, multiply 12 by 1.40 or 16.80 rounded off to 17 parts required.

(4) Subsequent changes to allowances will be limited as follows: No change in the range of items is authorized, If additional items are considered necessary, recommendation should be forwarded to the U. S. Army Mobility Equipment Command for exception or revision to the allowance list. Revisions to the range of items authorized will be made by the U.S. Army Mobility Equipment Command based upon engineering experience, demand data, or TAERS information.

9. 30-Day DS Maintenance Allowances.

(1) The allowance columns are divided into three subcolumns. Indicated in each subcolumn, opposite the first appearance of each item, is the total quantity of items authorized for the number of equipments supported. Subsequent appearances of the same item will have the letters "REF" in the applicable allowance column. To locate the referenced item locate the FSN or reference number in the index. The earliest figure and item number is the referenced item. Items authorized for use as required but not for initial stockage are identified with an asterisk in the allowance column.

(2) The quantitative allowances for DS level of maintenance will represent initial stockage for a 30-day period for the number of equipments supported.

(3) To determine allowances when supporting more than 100 of these equipments. First, divide the number of equipments supported by 100 by moving the decimal two places left. ~~Second~~, multiply the result by the quantity in the 51-100 density column. Example, authorized allowance for 51-100 equipments is 40; for 150 equipments multiply 40 by 1.50 or 60 parts required.

h. 1-Year Allowance Per 100 Equipments/Contingency Planning Purpose. Indicates opposite the first appearance of each item the total quantity required for distribution and contingency planning purposes, The range of items indicates total quantities of all authorized items required to provide for adequate support of 100 equipments for one year. Subsequent appearances of the same item will have the letters "REF" in the allowance column.

i. Illustration. This column is divided as follows:

(1) **Figure number.** Indicates the figure number of the illustration in which the item is shown.

(2) **Item number.** Indicates the callout number used to reference the item in the illustration.

C-4. Special Information

a. Repair parts mortality has been based on 800 hours operation per year.

b. Parts which require manufacture or assembly at a category higher than that authorized for installation will indicate in the source column the higher category.

c. The same illustration. is used to illustrate the repair parts listed in both organizational maintenance section and direct support maintenance section.

C-5. How to Locate Repair Parts

a. When Federal stock number or reference number is unknown:

(1) **First.** Using the table of contents determine the assembly group within the repair part belongs. This is necessary since illustrations are prepared for assembly groups, and listings are divided into the same groups.

(2) **Second.** Find the illustration covering the assembly group to which the repair part belongs.

(3) **Third.** Identify the repair part on the illustration and note the illustration figure and item number of the repair part.

(4) **Using the Repair Parts Listings,** find the assembly group to which the repair part belongs and locate the illustration figure and item number noted on the illustration.

b. When Federal stock number or reference is known:

(1) First. Using the Index of Federal Stock Numbers and Reference Numbers find the pertinent Federal stock number or reference number. This index is in ascending FSN sequence followed by a list of reference numbers in alpha-numeric sequence, cross-referenced to the illustration figure number and item number.

(2) Second. Using the Repair Parts Listing, find the assembly group of the repair part and the illustration figure number and item number referenced in the Index of Federal Stock Numbers and Reference Numbers.

c. When the Federal stock number or reference number is known and the repair part is not illustrated:

(1) First. Using the Index of Federal Stock Numbers and Reference Numbers find the pertinent Federal stock number or reference number in the section titled Items not Illustrated and note the group number. This section is in ascending FSN sequence followed by a list of reference numbers in alpha-numeric sequence, cross-referenced to assembly group number.

(2) Second. Using the Table of Contents, locate the assembly group number and page number.

(3) Third. Using the applicable group number and page number, locate the pertinent stock number or reference number in the Repair Parts Listing. Items which are not illustrated are listed at the end of the assembly group to which they belong.

C-6. Abbreviations

Abbreviation	Explanation
hd	head
hex	hexagon
in	inch
lg	long

C-7. Federal Supply Codes for Manufacturers

Code	Manufacturer
14959	Crane Co.
30760	Ingersoll-Rand Co.
38443	Marlin-Rockwell Co.
60380	Torrington Co.
70270	Alemite Corp.
72962	Elastic Stop Nut Corp. of America
78945	United Screw and Bolt Corp.
83259	Parker Seal Co.
96906	Military Standards promulgated by standardization

SECTION II PRESCRIBED LOAD ALLOWANCE

(1) FEDERAL STOCK NUMBER	(2) DESCRIPTION useable on code	(3) 15-DAY ORG MAINT. ALW			
		(A)	(B)	(C)	(D)
		1-5	6-20	21-50	51-100
	GROUP 01				
340-116 5804	SHIM, IMPELLER COVER (30760) P251-145-3			2	2
340-116- 5822	SHIM, IMPELLER COVER (30760) P251-145-10			2	2
340-116 5805	SHIM, IMPELLER COVER (30760) P251-145-5			2	2
340-116- 5824	SHIM, IMPELLER COVER (P251-145-25			2	2

(1) SMR CODE	(2) FEDERAL STOCK NUMBER	(3) DESCRIPTION REF NUMBER & MFR CODE	(4) USABLE ON CODE	(5) UNIT OF MEAS QTY INC IN UNIT	(6) 15-DAY ORGANIZATIONAL MAINTENANCE ALW				(7) ILLUS- TRATION	
					(a)	(b)	(c)	(d)	(a)	(b)
					1-5	6-20	21-50	51-100	FIG. NO.	ITEM NO.
		SECTION III - REPAIR PARTS FOR ORGANIZATIONAL MAINTENANCE								
		GROUP 01 - SUMP PUMP								
X20		FITTING, GREASE 1958ALHYD (70270)		EA 2					1	3
P O	4730-826-6465	FITTING, LUBRICATION MS35670-2 (96906)		EA 1	*	*	*	*	1	5
X20		FILTER, VENT JA4-75 (30760)		EA 2					1	6
X20		PLUG, VENT FILTER JA4-71 (30760)		EA 1					1	7
X20		HANDLE, DEAD P250-48 (30760)		EA 1					1	12
X20		NIPPLE, STRAINER P35-286 (14959)		EA 1					1	31
P O	3820-119-0687	STRAINER, AIR P250A267 (30760)		EA 1	*	*	*	*	1	32
X20		CAP, STRAINER P250-268 (30760)		EA 1					1	33
P O	4730-374-6798	PLUG, STRAINER P25-536 (30760)		EA 1	*	*	*	*	1	34
P O	3820-119-0689	SCREEN, STRAINER 205-1061 (30760)		EA 1	*	*	*	*	1	35
X20		PLUG, OIL CHAMBER P25-227 (30760)		EA 1					1	37
X20		FILTER, VENT JA4-75 (30760)		EA 2					1	38
X20		PLUG, VENT FILTER JA4-71 (30760)		EA 1					1	39
X20		FITTING, GREASE 1958ALHYD (70270)		EA					1	40
X20		SCREW, CAP: IMPELLER COVER, 3/8-16 x 3 IN. LG PB25-146 (78945)		EA 4					1	49
X20		WASHER, LOCK: IMPELLER COVER, 3/8 IN. D02-321 (78945)		EA 4					1	50
P O	3820-119-0691	INLET: IMPELLER PB25-148B (30760)		EA 1	*	*	*	*	1	51
P O	3820-119-0692	COVER, IMPELLER P251-144 (30760)		EA 1	*	*	*	*	1	52
P O	5340-116-5804	SHIM: IMPELLER COVER, .003 IN., .076 MM THK, GREEN P251-145-3 (30760)		EA 1	*	*	2	2	1	53
P O	5340-116-5805	SHIM: IMPELLER COVER, .005 IN., .127 MM THK, BLUE PB251-145-5 (30760)		EA 1	*	*	2	2	1	53
P O	5340-116-5822	SHIM: IMPELLER COVER, .010 IN., .254 MM THK, BROWN P251-145-10 (30760)		EA 1	*	*	2	2	1	53
P O	5340-116-5824	SHIM: IMPELLER COVER, .025 IN., .636 MM THK, WHITE P251-145-25 (30760)		EA 1	*	*	2	2	1	53
X20		CAP, GREASE CHAMBER P250-545 (30760)		EA 1					1	65

(1) SMR CODE	(2) FEDERAL STOCK NUMBER	(3) DESCRIPTION	(4) USABLE ON CODE	(5) QTY INC IN UNI	(6) 15-DAY ORGANIZATIONAL MAINTENANCE ALW				(7) ILLUS- TRATION	
					(a)	(b)	(c)	(d)	(a) FIG NC	(b) ITEM NO.
					1-5	6-20	21-5	1-10		
120		SEAL, CAP R2C103 (83259)	A						1	6
120		BUSHING, REDUCING C10-284 (30760)	A							
120		ADAPTER, EXHAUST VMP77 (30760)	A							
120		ADAPTER, FIRE HOSE P25-183 (30760)	A							
120		COUPLING, HOSE UM75M (73273)	A							

(1) SMR CODE	(2) FEDERAL STOCK NUMBER	(3) DESCRIPTION REF NUMBER & MFR CODE	(4) USABLE ON CODE	(5) QTY INC IN UNIT	(6) 30-DAY DS MAINT ALLOWANCE			(7) 1-YR ALW PER 100 EQUIP CNTGY	(8) ILLUS- TRATION	
					(a)	(b)	(c)		(a)	(b)
					1-20	21-50	51-100		FIG. NO.	ITE. NO.
		SECTION V - REPAIR PARTS FOR DS MAINTENANCE								
		GROUP 01 - SUMP PUMP								
' F	3820-120-0096	HOUSING, MOTOR P251-40 (30760)	EA	1	*	*	*	5	1	
' F	3120-118-6266	BUSHING, IMPELLER HUB P250-41 (30760)	EA	1	*	*		2	10	1
20		FITTING, GREASE 1958ALHYD (70270)	EA	2						1
' F	5330-116-5833	SEAL, WATER PB250-153 (30760)	EA	2	2	2	4	50		1
' O	4730-826-6465	FITTING: LUBRICATION MS35670-2 (96906)	EA	1	*	*	*	5		1
20		FILTER, VENT JA4-75 (30760)	EA	2						1
20		PLUG, VENT FILTER JA4-71 (30760)	EA	1						1
2F		END PLATE, FRONT P250-11 (30760)	EA	1						1
' F	5310-119-4653	PACKING, ARBOR P25-35 (30760)	EA	1	2	2	4	50		1
F	5340-116-7798	RETAINER, ARBOR P250-36 (30760)	EA	2	2	2	2	25		1 1
' F	5130-022-3595	VANE R5H42 (30760)	EA	4	2	2	2	24		1 1
20		HANDLE, DEAD P250-48 (30760)	EA	1						1 1
2F		DOWEL, CYLINDER P250-98 (30760)	EA	1						1 1
F	3820-120-0094	END PLATE, REAR P251-12 (30760)	EA	1	*	*		2	10	1 1
F	5330-116-7763	GASKET, HOUSING P250-43 (30760)	EA	1	2	2	2	25		1 1
2F		NUT, HOUSING JA4-282 (30760)	EA	1						1 1
F	5130-429-8429	GOVERNOR R4FA424 (30760)	EA	1	*	*		2	10	
1		BODY, GOVERNOR R4-424B (30760)	EA	1						1 1
1		PIN GOVERNOR Q83305 (60380)	EA	2						1 1
2F	5310-496-6330	WASHER, GOVERNOR STEM R4-416 (30760)	EA	1						1 1
1		WEIGHT, GOVERNOR R4-420B (30760)	EA	2						1 2
F	3820-119-0694	STEM, GOVERNOR R4-430A (30760)	EA	1	*	*	*	5		1 2
1		PIN GOVERNOR Q83305 (60380)	EA	1						1 2
F	5340-496-6297	SPRING, GOVERNOR R2-422B (30760)	EA	1	*	*		2	10	1 2
2F		NUT: GOVERNOR ADJUSTING R2-427 (30760)	EA	1						1 2

(1) SMR CODE	(2) FEDERAL STOCK NUMBER	(3) DESCRIPTION REF NUMBER & MFR CODE	(4) USABLE ON CODE	(5) TY PC 4 NIT	(6) 30-DAY DS MAINT ALLOWANCE			(7) 1-YR ALW PER 100 QUIP NTGY	(8) ILLUS- TRATION	
					(a)	(b)	(c)		(a)	(b)
					-20	1-50	1-100		IG. IO.	EM IO.
X2F		SPACER: ARBOR BEARING P251-165 (30760)	EA	1				1	25	
P F	1110-116-5799	BEARING, REAR: ARBOR R4-24 (30760)	EA	1	*	2	2	20	1 26	
P F	1820-120-0093	VALVE, GOVERNOR P35-425 (30760)	EA	1	*	*	*	5	1 27	
P F	1340-344-8552	SPRING, GOVERNOR VALVE P35-431 (30760)	EA	1	*	*	2	10	1 28	
P F	1340-116-5825	EAT, GOVERNOR SPRING P25-418 (30760)	EA	1	*	*	*	5	1 29	
P F	1320-344-8550	SPRING, SEAT RETAINING H80-81B (30760)	EA	1	*	*	2	10	1 30	
K20		WIPPLE, STRAINER P35-286 (14959)	EA	1					1 31	
P O	1820-119-0687	STRAINER, AIR P250A267 (30760)	EA	1	*	*	*	5	1 32	
K20		CAP, STRAINER P250-268 (30760)	EA	1					1 33	
P O	1730-374-6798	PLUG, STRAINER P25-536 (30760)	EA	1	*	*	*	5	1 34	
P O	1820-119-0689	SCREEN, STRAINER 205-1061 (30760)	EA	1	*	*	*	5	1 35	
P F	1820-119-0690	WACKHEAD P250-102 (30760)	EA	1	*	*	*	5	1 36	
K20		PLUG, OIL CHAMBER P25-227 (30760)	EA	1					1 37	
K20		FILTER, VENT JAA-75 (30760)	EA	2					1 38	
K20		PLUG, VENT FILTER JAA-71 (30760)	EA	1					1 39	
K20		FITTING, GREASE 1958ALHYD (70270)	EA	1					1 40	
X1	1120-429-9399	BUSHING, GOVERNOR VALVE P35-429 (30760)	EA	1					1 41	
X2F		ROTOR P251-53 (30760)	EA	1					1 42	
X2F		CYLINDER P250-3 (30760)	EA	1					1 43	
X2F		BEARING, FRONT: ARBOR MRC304SFDB (38443)	EA	1					1 44	
X2F		SPACER: IMPELLER P250-152 (30760)	EA	1					1 45	
P F	1340-116-7781	SHIM: IMPELLER, .005 IN., .127 MM THK P25-151-15 (30760)	EA	3	2	2	4	50	1 46	
P F	1340-116-7782	SHIM: IMPELLER, .010 IN., .254 MM THK P25-151-10 (30760)	EA	3	2	2	4	50	1 46	
P F	1310-116-7803	SHIM: IMPELLER, .025 IN., .635 MM THK P25-151-25 (30760)	EA	3	2	2	4	50	1 46	
X2F		ARBOR P251-4 (30760)	EA	1					1 47	
X2F		KEY: IMPELLER P25-150 (30760)	EA	1					1 48	

(1) SMR CODE	(2) FEDERAL STOCK NUMBER	(3) DESCRIPTION REF NUMBER & MFR CODE	(4) USABLE ON CODE	(5) QTY NC IN UNIT	(6) 30-DAY DS MAINT ALLOWANCE			(7) 1-YR ALW PER 100 EQUIP CNTGY	(8) ILLUS- TRATION		
					(a)	(b)	(c)		(a)	(b)	
					1-20	21-50	51-100		FIG. NO.	ITEM NO.	
X20		SCREW, CAP: IMPELLER COVER, 3/8-16 x 3 IN. LG PB25-146 (78945)		EA	4					1	49
X20		WASHER, LOCK: IMPELLER COVER, 3/8 IN. D02-321 (78945)		EA	4					1	50
P O	3820-119-0691	INLET: IMPELLER PB25-148B (30760)		EA	1	*	*	*	5	1	51
P O	3820-119-0692	COVER, IMPELLER P251-144 (30760)		EA	1	*	*	*	5	1	52
P O	5340-116-5804	SHIM: IMPELLER COVER, .003 IN., .076 MM THK, GREEN P251-145-3 (30760)		EA	1	2	2	2	25	1	53
P O	5340-116-5805	SHIM: IMPELLER COVER, .005 IN., .127 MM THK, BLUE PB251-145-5 (30760)		EA	1	2	2	2	25	1	53
P O	5340-116-5822	SHIM: IMPELLER COVER, .010 IN., .254 MM THK, BROWN P251-145-10 (30760)		EA	1	2	2	2	25	1	53
P O	5340-116-5824	SHIM: IMPELLER COVER, .025 IN., .636 MM THK, WHITE P251-145-25 (30760)		EA	1	2	2	2	25	1	53
K2F		NUT: ARBOR 99K1-080-97 (72962)		EA	1					1	54
K2F		WASHER, ARBOR NUT P35-157 (30760)		EA	1					1	55
P F	3820-119-0693	IMPELLER P250-143 (30760)		EA	1	*	2	2	20	1	56
P F	5310-116-7804	SEAT, BEARING P250-115 (30760)		EA	1	*	*	*	5	1	57
P F	2990-691-1180	SPRING, ARBOR BEARING 9EM278 (30760)		EA	1	*	2	2	20	1	58
K2F		SCREW, CAP, HEXAGON HEAD: 5/16-18 x 1 1/4 IN. LG SP9-11B (78945)		EA	1					1	59
K2F		WASHER, LOCK: 5/16 IN. T11-58 (78945)		EA	1					1	60
K2F		WASHER, PACKING P250-543 (30760)		EA	1					1	61
P F	5330-118-2947	PACKING, PLUNGER P250-542 (30760)		EA	1	2	2	4	50	1	62
P F	5340-117-4759	SPRING, PLUNGER P250-541 (30760)		EA	1	*	*	2	10	1	63
K2F		PLUNGER, GREASE P250-540 (30760)		EA	1					1	64
K2O		CAP, GREASE CHAMBER P250-545 (30760)		EA	1					1	65
K2O		SEAL, CAP R2C103 (83259)		EA	1					1	66
K2O		BUSHING, REDUCING C10-284 (30760)		EA	1						
K2O		ADAPTER, EXHAUST VMP77 (30760)		EA	1						
K2O		ADAPTER, FIRE HOSE P25-183 (30760)		EA	1						
K2O		COUPLING, HOSE UM75M (73273)		EA	1						

INDEX - FEDERAL STOCK NUMBER AND REFERENCE NUMBER CROSS-REFERENCE TO FIGURE AND ITEM NUMBER

<u>STOCK NUMBER</u>	<u>FIGURE No.</u>	<u>ITEM No.</u>	<u>STOCK NUMBER</u>	<u>FIGURE No.</u>	<u>ITEM No.</u>
2990-691-1180	1	58	5310-116-7804	1	57
3110-116-5799	1	26	5310-119-4653	1	9
3120-118-6266	1	2	5310-496-6330	1	19
3120-429-9399	1	41	5330-116-5833	1	4
3820-119-0687	1	32	5330-116-7763	1	15
3820-119-0689	1	35	5330-118-2947	1	62
3820-119-0690	1	36	5340-116-5804	1	53
3820-119-0691	1	51	5340-116-5805	1	53
3820-119-0692		52	5340-116-5822	1	53
3820-119-0693		56	5340-116-5824	1	53
3820-119-0694		21	5340-116-5825	1	29
3820-120-0093	1	27	5340-116-7803	1	46
3820-120-0094	1	14	5340-116-7781	1	46
3820-120-0096	1	1	5340-116-7782	1	46
4320-344-8550	1	30	5340-116-7798	1	10
4730-374-6798	1	34	5340-117-4759	1	63
4730-826-6465	1	5	5340-344-8552	1	28
5310-022-3595	1	11	5340-496-6297	1	23

<u>REFERENCE No.</u>	<u>Mfg CODE</u>	<u>FIG No.</u>	<u>ITEM No.</u>	<u>REFERENCE No.</u>	<u>Mfg CODE</u>	<u>FIG No.</u>	<u>ITEM No.</u>
D02-321	78945	1	50	P250-545	30760	1	65
H80-81B	30761	1	30	P250-98	30760	1	13
JA4-282	30761	1	16	P251-12	30760	1	14
JA4-71	30761	1	7	P251-144	30760	1	52
JA4-75	30761	1	39	P251-145-10	30760	1	53
			6	P251-145-25	30760	1	53
			38	P251-145-3	30760	1	53
MRC304SFDB	38443	1	44	P251-165	30760	1	25
MS35670-2	96906	1	5	P251-4	30760	1	47
PB25-146	78945	1	49	P251-40	30760	1	1
PB25-148B	30760	1	51	P251-53	30760	1	42
PB250-153	30760	1	4	P35-157	30760	1	55
PB251-145-3	30760	1	53	P35-286	14959	1	31
PB251-145-5	30760	1	53	P35-425	30760	1	27
P25-150	30760	1	48	P35-429	30760	1	41
P25-151-10	30760	1	46	P35-431	30760	1	28
P25-151-15	30760	1	46	P4-424B	30760	1	17
P25-151-25	30760	1	46	Q83305	60380	1	18
P25-227	30760	1	37			1	22
P25-35	30760	1	9	R2-427	30760	1	24
P25-418	30760	1	29	R2C103	83259	1	66
P25-536	30760	1	34	R4-24	30760	1	26
P250A267	30760	1	32	R4-416	30760	1	19
P250-102	30760	1	36	R4-420B	30760	1	20
P250-11	30760	1	8	R4-430A	30760	1	21
P250-115	30760	1	57	R5H42	30760	1	11
P250-143	30760	1	56	SP9-11B	78945	1	59
P250-152	30760	1	45	T11-58	78945	1	60
P250-268	30760	1	33	1958ALHYD	70270	1	3
P250-3	30760	1	43		70270	1	40
P250-36	30760	1	10	205-1061	30760	1	35
P250-40	30760	1	2	9BM278	30760	1	58
P250-43	30760	1	15	99K1-080-97	72962	1	54
P250-48	30760	1	12				
P250-540	30760	1	64				
P250-541	30760	1	63				
P250-542	30760	1	62				
P250-543	30760	1	61				

ITEMS NOT ILLUSTRATED

<u>REFERENCE No.</u>	<u>Mfg CODE</u>	<u>GROUP No.</u>
C10-284	30760	01
VMP77	30760	01
P25-183	30760	01
UM75M	73273	01
R4FA424	30760	01

By Order of the Secretary of the Army:

Official:

KENNETH G. WICKHAM,
Major General, United States Army,
The Adjutant General.

W. C. WESTMORELAND,
General, United States Army,
Chief of Staff.

DISTRIBUTION:

To be distributed in accordance with DA Form 12-25, Section I,
(qty rqr block no. 242) Organizational Maintenance requirements for
Pumps, Centrifugal: Fresh Water.

RECOMMENDED CHANGES TO EQUIPMENT TECHNICAL PUBLICATIONS



THEN...JOT DOWN THE
DOPE ABOUT IT ON THIS FORM.
CAREFULLY TEAR IT OUT, FOLD IT
AND DROP IT IN THE MAIL.

SOMETHING WRONG WITH PUBLICATION

FROM: (PRINT YOUR UNIT'S COMPLETE ADDRESS)

DATE SENT

PUBLICATION NUMBER

PUBLICATION DATE

PUBLICATION TITLE

BE EXACT PIN-POINT WHERE IT IS

PAGE
NO.

PARA-
GRAPH

FIGURE
NO.

TABLE
NO.

IN THIS SPACE, TELL WHAT IS WRONG
AND WHAT SHOULD BE DONE ABOUT IT.

TEAR ALONG PERFORATED LINE

PRINTED NAME, GRADE OR TITLE AND TELEPHONE NUMBER

SIGN HERE

THE METRIC SYSTEM AND EQUIVALENTS

WEIGHT MEASURE

1 Centimeter = 10 Millimeters = 0.01 Meters = 0.3937 Inches
 1 Meter = 100 Centimeters = 1000 Millimeters = 39.37 Inches
 1 Kilometer = 1000 Meters = 0.621 Miles

WEIGHTS

1 Gram = 0.001 Kilograms = 1000 Milligrams = 0.035 Ounces
 1 Kilogram = 1000 Grams = 2.2 lb.
 1 Metric Ton = 1000 Kilograms = 1 Megagram = 1.1 Short Tons

LIQUID MEASURE

1 Milliliter = 0.001 Liters = 0.0338 Fluid Ounces
 1 Liter = 1000 Milliliters = 33.82 Fluid Ounces

SQUARE MEASURE

1 Sq. Centimeter = 100 Sq. Millimeters = 0.155 Sq. Inches
 1 Sq. Meter = 10,000 Sq. Centimeters = 10.76 Sq. Feet
 1 Sq. Kilometer = 1,000,000 Sq. Meters = 0.386 Sq. Miles

CUBIC MEASURE

1 Cu. Centimeter = 1000 Cu. Millimeters = 0.06 Cu. Inches
 1 Cu. Meter = 1,000,000 Cu. Centimeters = 35.31 Cu. Feet

TEMPERATURE

$5/9(^{\circ}\text{F} - 32) = ^{\circ}\text{C}$
 212° Fahrenheit is equivalent to 100° Celsius
 90° Fahrenheit is equivalent to 32.2° Celsius
 32° Fahrenheit is equivalent to 0° Celsius
 $9/5^{\circ}\text{C} + 32 = ^{\circ}\text{F}$

APPROXIMATE CONVERSION FACTORS

TO CHANGE	TO	MULTIPLY BY
Inches	Centimeters	2.540
Feet	Meters	0.305
Yards	Meters	0.914
Miles	Kilometers	1.609
Square Inches	Square Centimeters	6.451
Square Feet	Square Meters	0.093
Square Yards	Square Meters	0.836
Square Miles	Square Kilometers	2.590
Acres	Square Hectometers	0.405
Cubic Feet	Cubic Meters	0.028
Cubic Yards	Cubic Meters	0.765
Fluid Ounces	Milliliters	29.573
its	Liters	0.473
arts	Liters	0.946
allons	Liters	3.785
Ounces	Grams	28.349
Pounds	Kilograms	0.454
Short Tons	Metric Tons	0.907
Pound-Feet	Newton-Meters	1.356
Pounds per Square Inch	Kilopascals	6.895
Miles per Gallon	Kilometers per Liter	0.425
Miles per Hour	Kilometers per Hour	1.609

TO CHANGE	TO	MULTIPLY BY
Centimeters	Inches	0.394
Meters	Feet	3.280
Meters	Yards	1.094
Kilometers	Miles	0.621
Square Centimeters	Square Inches	0.155
Square Meters	Square Feet	10.764
Square Meters	Square Yards	1.196
Square Kilometers	Square Miles	0.386
Square Hectometers	Acres	2.471
Cubic Meters	Cubic Feet	35.315
Cubic Meters	Cubic Yards	1.308
Milliliters	Fluid Ounces	0.034
Liters	Pints	2.113
Liters	Quarts	1.057
ers	Gallons	0.264
ms	Ounces	0.035
ograms	Pounds	2.205
Metric Tons	Short Tons	1.102
Newton-Meters	Pounds-Feet	0.738
Kilopascals	Pounds per Square Inch	0.145
ometers per Liter	Miles per Gallon	2.354
ometers per Hour	Miles per Hour	0.621

